

# KP310V1.0 Controller Operation Manual



[www.kipor.com](http://www.kipor.com)

Version No.: KP310.1.1.0

July 20<sup>th</sup>, 2011

## Index

|     |   |        |
|-----|---|--------|
| 1.  | Brief Introduction.....                             | - 1 -  |
| 2.  | Model Nomenclature Explained .....                  | - 1 -  |
| 3.  | Performance and Features .....                      | - 1 -  |
| 4.  | Specifications .....                                | - 2 -  |
| 5.  | Operation.....                                      | - 3 -  |
|     | 5.1 Function of keys.....                           | - 3 -  |
|     | 5.2 Controller Layout.....                          | - 5 -  |
|     | 5.2.1 Main Display.....                             | - 6 -  |
|     | 5.2.2 “Parameters Set” menu .....                   | - 9 -  |
|     | 5.3 Manual Operation .....                          | - 10 - |
|     | 5.4 Remote Operation .....                          | - 11 - |
| 6.  | Protection .....                                    | - 11 - |
|     | 6.1 Alarm.....                                      | - 12 - |
|     | 6.2 Time delayed stop alarms.....                   | - 12 - |
|     | 6.3 Emergency stop alarms .....                     | - 13 - |
| 7.  | Wiring .....  | - 14 - |
| 8.  | Parameter Set .....                                 | - 15 - |
|     | 8.1 Parameters Set list.....                        | - 16 - |
|     | 8.2 Programmable output list .....                  | - 21 - |
|     | 8.2.1 Remote set.....                               | - 21 - |
|     | 8.2.2 Set Input .....                               | - 22 - |
|     | 8.3 Programmable output list .....                  | - 23 - |
| 9.  | Commission .....                                    | - 24 - |
| 10. | Applications .....                                  | - 24 - |
| 11. | Installations .....                                 | - 25 - |
| 12. | Trouble shooting .....                              | - 26 - |
| 13. | Serial Communication.....                           | - 26 - |
|     | 13.1 Physical Layer of Communication Protocol ..... | - 27 - |
|     | 13.2 Enquiry/ Response Period .....                 | - 27 - |
|     | 13.3 Comm RTU.....                                  | - 28 - |
|     | 13.3.1 Address field .....                          | - 28 - |
|     | 13.3.2 Function field .....                         | - 28 - |
|     | 13.3.3 Data field.....                              | - 28 - |
|     | 13.3.4 Data CRC field.....                          | - 28 - |
|     | Appendix 1 CRC16-CCITT Sheet .....                  | - 29 - |
|     | Appendix 2 CRC16-CCITT .....                        | - 30 - |
|     | Appendix 3 Wiring Diagram.....                      | - 31 - |
|     | 1) 3-Phase 4-Line .....                             | - 31 - |
|     | 2) 3-Phase 3-Line .....                             | - 32 - |
|     | 3) 1-Phase 2-Line .....                             | - 33 - |
|     | 4) 2-Phase 3-Line .....                             | - 34 - |

## 1. Brief Introduction

The KP310V1.0 controller has the function of manual/remote start and stop genset, data measurement, alarm and protection. The KP310V1.0 can display detailed genset running and alarming data through LED digit display in five numbers. RS232 interface with the host computer, can start, stop genset and display real-time running data through the host computer. The host computer software has the Chinese and English interface, featured by simple & reliable operation. RS485 interface is also available for remote monitor and control genset.

## 2. Model Nomenclature Explained

KP310V1.0

|                  |                  |
|------------------|------------------|
| <b>KP310V1.0</b> | KIPOR            |
| <b>KP310V1.0</b> | Controller Model |
| <b>KP310V1.0</b> | Version No.      |

## 3. Performance and Features

Main features:

- ☞ Microprocessor controller, higher hardware integration, higher reliable;
- ☞ Display through LED display in five digital numbers; convenient to test genset by touch buttons;
- ☞ Manual/remote start and stop genset;
- ☞ RS232 interface with PC to run and monitor genset; RS485 interface to remote monitor genset;
- ☞ Applied to 3-phase 4-line, 3-phase 3-line, 1-phase 2-line, double-voltage power sources;
- ☞ Monitor and display three-phase voltage, three-phase current, frequency, revolutions and battery voltage;
- ☞ Fault alarms, including over-voltage, under-voltage, over-frequency, under-frequency and charging fault;
- ☞ Protection against high water temperature and low oil voltage;
- ☞ All output interface are relay output;
- ☞ “Parameters Set” menu: parameters can be set by users through controllers or PC. All parameter are stored in internal flash memory so they won’t lose even the power turns off;
- ☞ Working voltage: 8-16VDC, adaptable to different batteries;
- ☞ Maintenance remind function (fuel filter, air filter, oil filter) ;
- ☞ Digital control, more reliable;
- ☞ Fault alarms are recorded until manual delete;
- ☞ Copy system configuration and restore system configuration, assure system can be restored due to wrong action;















☞ Modular structure, flame-retardant ABS shell, pluggable terminals, embedded installation, compact structure and easy installation

## 4. Specifications



|                        |   |
|------------------------|---|
| Working Voltage        | 12VDC (8~16VDC)   |
| Voltage measurement    | AC Input Voltage:<br>Phase voltage 10~290VAC RMS  |
|                        | Precision level: 2.0  |
|                        | Three-phase four-line<br>Three-phase three-line<br>Single-phase two-line<br>Double-voltage output simultaneously<br>Double-voltage output alternative |
|                        |   |
| Current measurement    | Primary current:<br>1A -900A (Parameters Set)   |
|                        | Secondary current:<br>5mA   |
|                        | Precision level:<br>2.0   |
| Frequency measurement  | Frequency range:<br>20~70HZ (voltage>15V)   |
|                        | Precision level:<br>0.5   |
| Revolution measurement | Voltage range:<br>5-50V   |
|                        | Max. frequency:<br>10000Hz  |
|                        | Flywheel tooth:<br>1-500  |
| Output                 | Fuel output relay:<br>15A/12VDC   |
|                        | Start output relay:<br>15A/12VDC  |
|                        | Preheat output relay:<br>5A/12VDC   |
|                        | Configuration output relay I :<br>5A/12VDC  |
|                        | Configuration output relay II :<br>5A/12VDC   |
| Ambient temperature    | -20~70°C  |

## 5. Operation



### 5.1 Function of keys

|   |                |   |
|---|----------------|---|
|    | Stop / Reset   | Genset is running, press  to stop genset, when genset is in alarming status, press  to reset.<br><br>In “System Set” mode, press  to return to the previous sub-menu. |
|    | Manu / ATS     | Press  to set genset in “Manual” Mode.<br><br>In “System Set” mode, press  to decrease the data value, equal to “-”.  |
|  | Remote Control | Press  to set genset in remote control mode.<br><br>In “System Set” mode, press  to increase the data value, equal to “+”.  |
|  | Start          | In “Manual” Mode, press  can start genset.   |
|  | Parameters Set | Press  to enter “Parameters Set” selection menu.   |

Note:

1 when the generator is stopped and in “Manual” Mode, press  and  for 5 seconds at the same time, it displays password “Test” mode . If user doesn't input the right password in 60 seconds, the system will automatically exit password menu and enters System Operation menu.

2 In “Parameters Set” menu, press ,  and  for 5 seconds in the same time to backup current system set, and the digital tube displays “Backup” for 2 seconds.

3 When genset is stopped, and in “Manual” Mode, press ,  and  for 5secs to restore system set, and the digital tube displays “Reset” for 2 seconds.





4 In the “Oil Filter Running Time” mode, press  for 5 seconds, it will clear alarm of oil filter

maintenance, and reset it.

5 In the “Fuel Filter Running Time” mode, press  for 5 seconds, it will clear alarm of fuel filter maintenance, and reset it.

6 In the “Air Filter Running Time” mode, press  for 5 seconds, it will clear alarm of air filter maintenance, and reset it.

7 In the “Running Time” mode, press  for 5 seconds, it will clear running time, and reset it.

8 Press  and  for 5 seconds until the signal twinkles, which shows that system has blocked some protection functions (over/under frequency, over/under voltage); then press   
and  for 5 seconds until the signal stop flickering, which shows that system has restored the protection functions (over/under frequency, over/under voltage).

## 5.2 Controller Layout

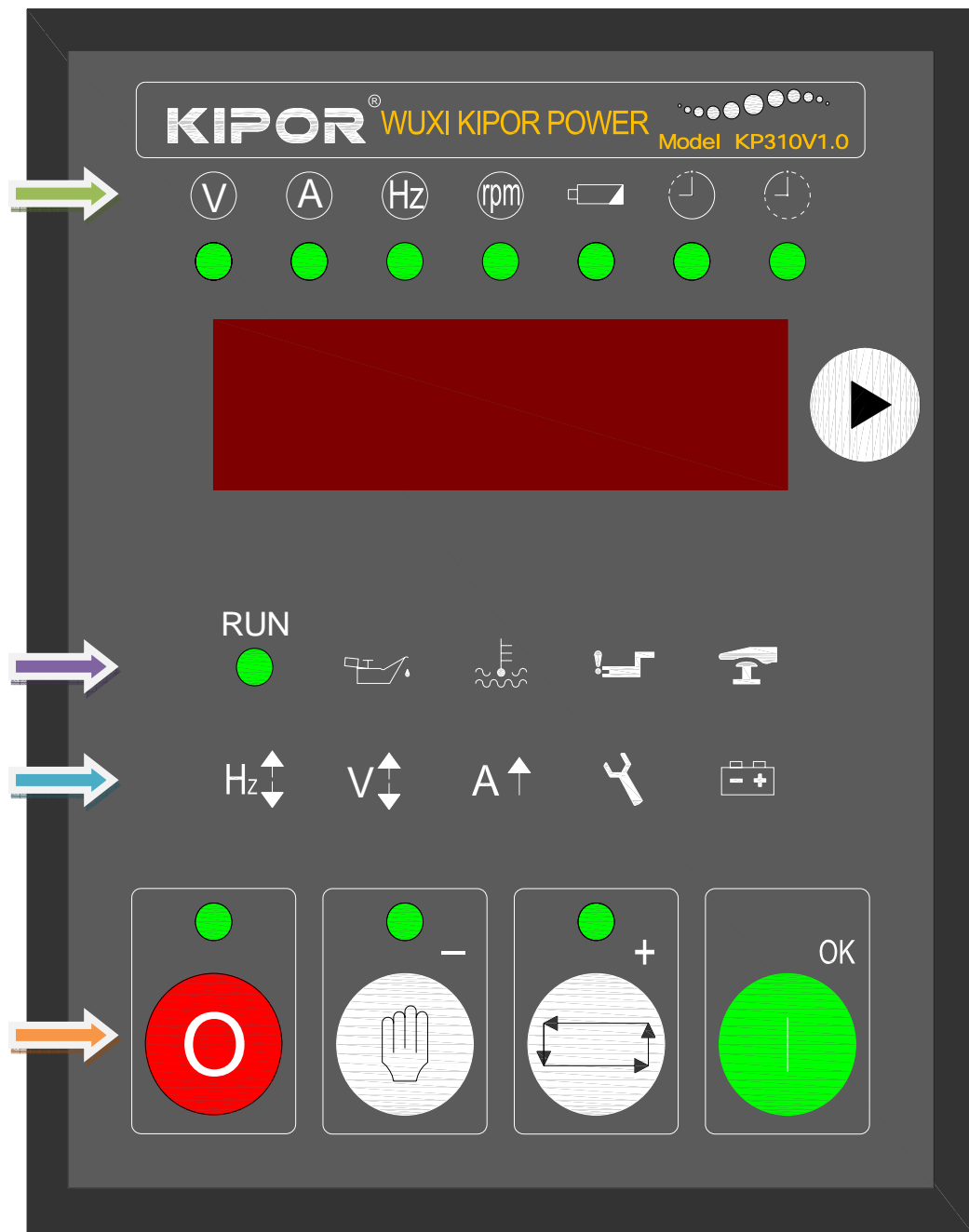

|  |                    |                  |                        |                  |                 |              |                  |
|--|--------------------|------------------|------------------------|------------------|-----------------|--------------|------------------|
|  | Voltage            | Current          | Frequency              | Revolutions      | Battery voltage | Running time | Maintenance time |
|  | Run                | Low Oil Pressure | High Water Temperature | Starting Failure | Emergency Stop  |              |                  |
|  | Frequency High/Low | Voltage High/Low | Current High/Low       | Maintenance      | Charge Failure  |              |                  |
|  | Stop               | Manual           | Remote                 | Start            |                 |              |                  |

## 5.2.1 Main Display

Press , it will display voltage, current, frequency, revolution, battery voltage, run time and maintenance time.

Note:

Battery charging voltage, switch value input/output state and system delay state is also available with RS232 Port.

### 5.2.1.1 LED Status Indication

Genset status and working mode will be displayed in LED Panel.

When genset is stopped,  will be lit up.

When genset is in “Manual” Mode,  will be lit up.

When genset is in remote control mode,  will be lit up.

### 5.2.1.2 Digital tube Status Indication

If genset switches to the following status, the digital tube will display genset status:

Preheat:



Start:

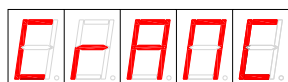

Starting idle:

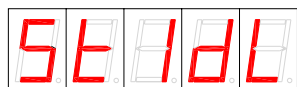

Stopping idle:



Stopping delay:

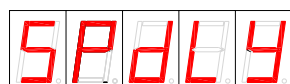



Press  to display running parameter, which shows as following:

**Voltage**

Three-phase four-line

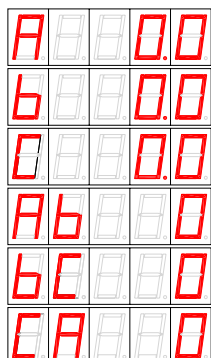

Three-phase three-line



Single-phase two-line

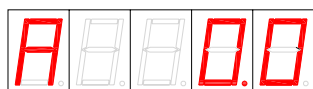

Two-phase three-line

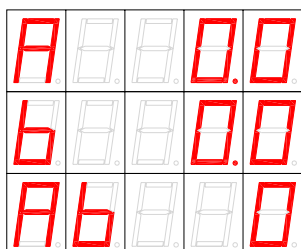

Double-voltage output alternative

120V output equals to single-phase two-line

240V output equals to two-phase three-line

**Current**

Three-phase four-line

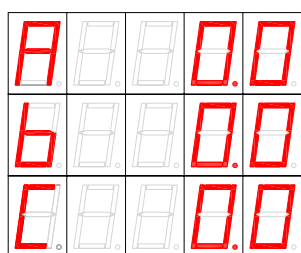

Three-phase three-line

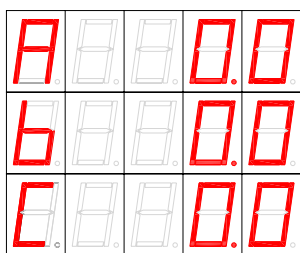

Single-phase two-line

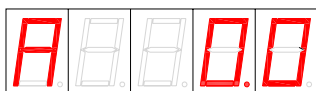

Two-phase three-line

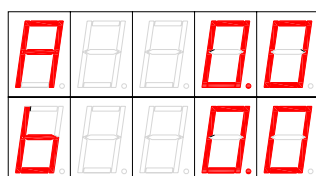

Double-voltage output alternative

120V output equals to single-phase two-line

240V output equals to two-phase three-line

**Frequency**

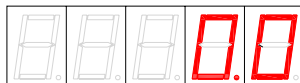

**Revolution**



⚠Note: If the “Revolution low” is set as zero, then the speed won’t be displayed..

**Battery voltage**

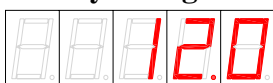

**Running time**



**Maintenance Time**

Oil filter

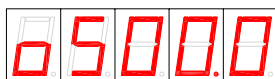

Fuel filter



Air filter

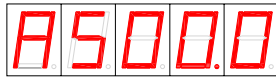



## 5.2.2 “Parameters Set” menu

The followings parameters are included in “Parameters Set” menu:





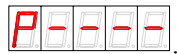

- ★NUMBER OF ENGINE FLYWHEEL
- ★TRIPPING SPEED
- ★TRIPPING FREQUENCY
- ★TRIPPING CHARGING VOLTAGE
- ★START TIMES
- ★TRIPPING OIL PRESSURE DELAY
- ★MAX. STARTING TIME
- ★UNDER SPEED
- ★OVER SPEED
- ★FAULT DELAY OF UNDER SPEED
- ★FAULT DELAY OF OVER SPEED
- ★DELAY TIME FROM STOP TO STANDBY
- ★PREHEAT TIME
- ★SECURITY DELAY
- ★AC SYSTEM
- ★CURRENT RATIO
- ★LOW FREQUENCY
- ★HIGH FREQUENCY
- ★UNDER VOLTAGE
- ★OVER VOLTAGE
- ★OVER CURRENT 1
- ★OVER CURRENT 2
- ★FAULT DELAY OF UNDER FREQUENCY
- ★FAULT DELAY OF OVER FREQUENCY
- ★FAULT DELAY OF UNDER VOLTAGE
- ★FAULT DELAY OF OVER VOLTAGE
- ★FAULT DELAY OF OVER CURRENT 1
- ★FAULT DELAY OF OVER CURRENT 2
- ★FAULT DELAY OF OVER CURRENT 3
- ★FAULT DELAY OF OVER CURRENT 4
- ★UNDER VOLTAGE OF BATTERY
- ★OVER VOLTAGE OF BATTERY
- ★COMMUNICATION ADDRESS
- ★MAINTENANCE TIME FOR FUEL FILTER
- ★MAINTENANCE TIME FOR AIR FILTER
- ★MAINTENANCE TIME FOR OIL FILTER
- ★REMOTE CONFIGURATION

- ★DELAY OF REMOTE START
- ★DELAY OF REMOTE STOP
- ★NUMBER OF REMOTE START
- ★INPUT 1 TYPE
- ★INPUT 1 FAULT DELAY
- ★INPUT 2 TYPE
- ★INPUT 2 FAULT DELAY
- ★CONFIGURATION INPUT 1
- ★CONFIGURATION INPUT 2
- ★START IDLE DELAY
- ★STOP IDLE DELAY
- ★PASSWORD



For example:

When genset is stopped, and is in “Manual” Mode, press  and  for 5 seconds at the same time, it displays password test mode



After inputting the right password, press  to enter the “Parameters Set” menu. Take the settings of flywheel tooth for example, after enter the flywheel tooth menu, press  to set the number, the default value is 100. While the value twinkles, press  or  to increase or decrease the value. After inputting the value, press  to confirm and save the value. Press  to get back to “Parameters Set” menu.

## 5.3 Manual Operation

When the KP310V1.0 controller is working, it is initialized to “Manual” Mode, with  indicator lighting. Press  or turn the ignition lock to start genset.

Start steps:

Preheat relay output, meanwhile the preheating timer start counting down. If the preheating time is set as zero, the preheat relay won't output.

After preheating, the preheating relay stop working, the fuel relay and starting relay begin to output. The maximum starting timer begins to count down. If genset can start successfully during the countdown, the starting relay stops outputting. If failed, the fuel relay and starting relay stop

outputting.

After starting genset, the security delay countdown timer works. During the security delay range, low oil voltage, high temperature, under speed, under voltage, under frequency and battery charging fault are allowed. When the configuring output is set as “4-Genset Idle”, and starting idle time isn’t 0, the related configuring output relay outputs, the start idle timer counting down, and generator is in idle mode.

After the starting idle status, the configuring output relay stop working and genset start to work in rated status.

Press  to stop genset.

## 5.4 Remote Operation

When the KP310V1.0 controller is working, it is initialized to the “Manual” Mode. Press  to login into the remote mode.

Start steps:

Preheat relay output, meanwhile the preheating timer start counting down. If the preheating time is set as zero, the relay won’t output.

After preheating, the preheating relay stop working, the fuel relay and starting relay begin to output. The maximum starting timer begins to count down. If genset can start successfully during the countdown, the starting relay stops outputting. If failed, the fuel relay and starting relay stop outputting.

After starting genset, the security delay countdown timer works. During the security delay range, low oil voltage, high temperature, under speed, under voltage, under frequency and battery charging fault are allowed. When the configuring output is set as “4-Generator Idle”, and starting idle time isn’t 0, the related configuring output relay outputs, the idle time start counting down, and generator is in idle mode.







Press remote stop key to stop genset.

## 6. Protection

KP310V1.0 controller has a lot of protection functions. When genset has some problems, relevant fault LED alarms. The fault alarm includes three types: warning, delay shutdown, immediately shutdown.



## 6.1 Alarm

In the following alarms, relevant LED twinkles, but genset keeps running.

| No. | Type                  | Description  |
|-----|-----------------------|--|
| 1   | Oil filter overtime   | When oil filter is overtime than the maintenance value, there will be an oil filter overtime alarm, maintenance LED  twinkles.  |
| 2   | Fuel filter overtime  | When fuel filter is overtime than the maintenance value, there will be a fuel filter overtime alarm, maintenance LED  twinkles. |
| 3   | Air filter overtime   | When air filter is overtime than the maintenance value, there will be a air filter overtime alarm, maintenance LED  twinkles.   |
| 4   | Over battery voltage  | When the battery voltage is larger than the set value, battery LED  twinkles.   |
| 5   | Under battery voltage | When the battery voltage is lower than the set value, battery LED  twinkles.   |
| 6   | Charging faults       | When the charging voltage is lower than the set value, battery LED  twinkles.   |

## 6.2 Time delayed stop alarms











After detecting the time delayed stop alarms, relevant LED twinkles, and genset will be stopped after a delayed time.

| No. | Type           | Description   |
|-----|----------------|---|
| 1   | Over Current 1 | If genset current is larger than Over Current 1, over current LED  twinkles, genset will be stopped after a delayed time.<br>Customers can set values to disable the protection. |
| 2   | Over Current 2 | If genset current is larger than Over Current 2, over current LED  twinkles, genset will be stopped after a delayed time.<br>Customers can set values to disable the protection. |

□Note: if output configuration is set as “8-Time delayed stop alarms”, breaker will be open in event of over current fault, and genset will be stopped after a delayed time.

## 6.3 Emergency stop alarms

After detecting the emergency stop alarms, relevant LED twinkles, and genset will be stopped instantly. Buzzer will give alarms.

| No. | Type                   | Description   |
|-----|------------------------|---|
| 1   | Over Frequency         | If genset frequency is larger than the set value, over frequency LED  twinkles, genset will be stopped instantly.<br>Customers can set values to disable the protection. |
| 2   | Under Frequency        | If genset frequency is lower than the set value, under frequency LED  twinkles, genset will be stopped instantly.<br>Customers can set values to disable the protection. |
| 3   | Over Voltage           | If genset voltage is larger than the set value, over voltage LED  twinkles, genset will be stopped instantly.<br>Customers can set values to disable the protection.     |
| 4   | Under Voltage          | If genset voltage is lower than the set value, under voltage LED  twinkles, genset will be stopped instantly.<br>Customers can set values to disable the protection.     |
| 5   | Over Frequency         | If genset frequency is larger than the set value, over frequency LED  twinkles, genset will be stopped instantly.  |
| 6   | Under Frequency        | If genset frequency is lower than the set value, under frequency LED  twinkles, genset will be stopped instantly.  |
| 7   | Low Oil Pressure       | If oil pressure is lower than the set value, low oil pressure LED  twinkles, genset will be stopped instantly.   |
| 8   | High Water Temperature | If water temperature is higher than the set value, high water temperature LED  twinkles, genset will be stopped instantly.   |
| 9   | Start failure          | If genset failed to start in the set time, start failure LED  twinkles, genset will be stopped instantly.  |
| 10  | Emergency Stop         | While press the emergency stop button, emergency stop LED  twinkles, genset will be stopped instantly.   |

□Note:

- 1、“Over frequency” protection can be disabled if “over frequency alarm delay time” is set as 0.
- 2、“Under frequency” protection can be disabled if “under frequency alarm delay time” is set as 0.

## 7. Wiring

The back panel of KP310V1.0 controller is as follows:

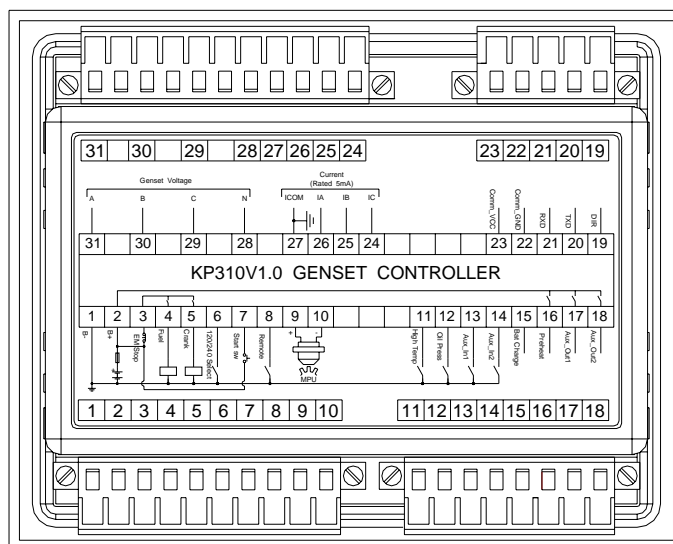

Description of wiring terminals:

| No. | Function                           | Diameter           | Note   |
|-----|------------------------------------|--------------------|--|
| 1   | DC Working power input: B-         | 1.0mm <sup>2</sup> | Connect with the battery cathode                               |
| 2   | DC Working power input: B+         | 1.0mm <sup>2</sup> | Connect with the battery anode                                 |
| 3   | Emergency stop input               | 1.0mm <sup>2</sup> | Connect with B+ with emergency stop button                     |
| 4   | Fuel relay output                  | 1.0mm <sup>2</sup> | Rated current:15A, provide B+ by port 3                        |
| 5   | Start relay output                 | 1.0mm <sup>2</sup> | Rated current:15A, provide B+ by port 3                        |
| 6   | Dual voltage selection input       | 1.0mm <sup>2</sup> | Active if lower voltage circuit is closed                      |
| 7   | Ignition lock start input          | 1.0mm <sup>2</sup> | Connect to the ignition lock start terminal                    |
| 8   | Remote control input               | 1.0mm <sup>2</sup> | Remote input terminal, low voltage active                      |
| 9   | Revolution sensor input +          | 1.0mm <sup>2</sup> | Recommend to connect the revolution sensor with shielding wire |
| 10  | Revolution sensor input -          | 1.0mm <sup>2</sup> |  |
| 11  | Water temperature switch input     | 1.0mm <sup>2</sup> | Connect with water temperature sensor                          |
| 12  | Oil pressure switch input          | 1.0mm <sup>2</sup> | Connect with oil pressure sensor 连接机油压力传感器                     |
| 13  | Programmable configuration input 1 | 1.0mm <sup>2</sup> | Provide B+ by port 2   |
| 14  | Programmable configuration input 2 | 1.0mm <sup>2</sup> | Provide B+ by port 2   |
| 15  | Charging voltage detect            | 1.0mm <sup>2</sup> | Connect with generator D+ terminal                             |
| 16  | Preheat relay output               | 1.0mm <sup>2</sup> | Normal open output, rated current: 1A, provide B+ by port 2    |
| 17  | Programmable relay output 1        | 1.0mm <sup>2</sup> | Normal open output, rated current: 1A                          |



|    |   |                    |  |
|----|---|--------------------|--|
| 18 | Programmable relay output 2                 | 1.0mm <sup>2</sup> | Normal open output, rated current: 1A  |
| 19 | Communication port-DIR                      | 1.0mm <sup>2</sup> | Genset can communicate with PC through RS232 communication adapter.<br><br>Genset can communicate with remote controller through RS485 communication adapter |
| 20 | Communication port-TXD                      | 1.0mm <sup>2</sup> |  |
| 21 | Communication port-RXD                      | 1.0mm <sup>2</sup> |  |
| 22 | Communication port-GND                      | 1.0mm <sup>2</sup> |  |
| 23 | Communication port-VCC                      | 1.0mm <sup>2</sup> |  |
| 24 | Current transformer C phase detecting input | 1.0mm <sup>2</sup> | Connect with CT secondary wiring (Rated current: 5mA)  |
| 25 | Current transformer B phase detecting input | 1.0mm <sup>2</sup> | Connect with CT secondary wiring (Rated current: 5mA)  |
| 26 | Current transformer A phase detecting input | 1.0mm <sup>2</sup> | Connect with CT secondary wiring (Rated current: 5mA)  |
| 27 | Current transformer common terminal         | 1.0mm <sup>2</sup> | Refer to the description on the back of controller.  |
| 28 | Generator N phase voltage input             | 1.0mm <sup>2</sup> | Connect with N wire  |
| 29 | Generator C phase voltage input             | 1.0mm <sup>2</sup> | Connect with the C wire (4A fuse)  |
| 30 | Generator B phase voltage input             | 1.0mm <sup>2</sup> | Connect with the B wire (4A fuse)  |
| 31 | Generator A phase voltage input             | 1.0mm <sup>2</sup> | Connect with the A wire (4A fuse)  |

## 8. Parameter Set

After login into the Parameter Set menu, remote mode lighter twinkles, parameters will be displayed on the controller.



Press  to return to “System Operation” menu.

Press  or  to select parameters.

Press  to set parameters

Press  to return to “System Operation” menu.

Press  and  to plus or minus values.

Press  or  for long time to plus or minus values automatically.

Press  to save the data, and exit the parameters set.

If there is no operation for more than 60s, system will automatically exit Parameter Set menu, and enter the System Operation menu.

## 8.1 Parameters Set list

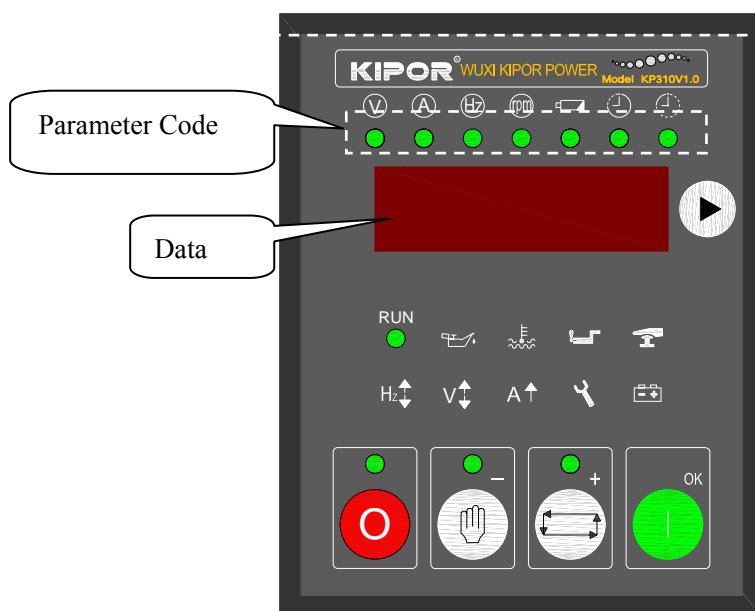

| No.           | Parameters                  | Code   | Range    | Accuracy | Defaults | Description  |
|---------------|-----------------------------|--------|----------|----------|----------|--|
| <b>Engine</b> |                             |        |          |          |          |  |
| 1             | Flywheel Gears              | ○○○○●  | 1-500    | 1        | 100      |  |
| 2             | Tripping speed              | ○○○○●○ | 0-3000   | 1rpm     | 600      | Engine RPM when starter is tripping                  |
| 3             | Tripping frequency          | ○○○○●● | 0-600    | 0.1Hz    | 200      | Genset Frequency when starter is tripping            |
| 4             | Tripping charging voltage   | ○○●○○  | 0-400    | 0.1V     | 50       | Charging alternator voltage when starter is tripping |
| 5             | Starting timer              | ○○●○○● | 1-100    | 0.1s     | 5        | Genset start timer                                   |
| 6             | Tripping oil pressure delay | ○○●○○○ | 1-100    | 0.1s     | 5        | Oil pressure when starter is tripper                 |
| 7             | Maximum starting time       | ○○●○○● | 1-100    | 0.1s     | 30       | Average starter working Time                         |
| 8             | Under RPM                   | ○○●○○○ | 0-6000   | 1rpm     | 0        | Engine under speed                                   |
| 9             | Over RPM                    | ○○●○○● | 0-6000   | 1rpm     | 1600     | Engine over speed                                    |
| 10            | Under RPM fault delay       | ○○●○○○ | 0-65535  | 0.1s     | 0        | Engine under speed delay                             |
| 11            | Over RPM fault delay        | ○○●○○● | 0-65535  | 0.1s     | 0        | Engine over speed delay                              |
| 12            | Engine Stop To Start Delay  | ○○●○○○ | 10-65535 | 0.1s     | 30       | Engine Stop to start delay timer                     |

|           |                             |        |         |        |      |  |
|-----------|-----------------------------|--------|---------|--------|------|--|
| 13        | Preheat delay               | ○○●●●● | 0-100   | 0.1s   | 50   | Set Output 1 or Set Output 2 is setted as “ Genset Preheat ”, it works when genset starts, controller start to count down..          |
| 14        | Safety Delay                | ○○●●●○ | 20-255  | 0.1s   | 60   | Within the safety delay, under oil pressure, high water temperature, under speed 、 under voltage 、 under frequency 、 charging fault. |
| Generator |                             |        |         |        |      |  |
| 15        | Phase Type                  | ○○●●●● | 0-4     | 1      | 0    | 0- 3-Phase 4-Line/3P4L<br>1- 3-Phase 3-Line/3P3L<br>2- 1-Phase 2-Line/1P2L<br>3- Double voltage<br>4- Double voltage select          |
| 16        | Current Ratio               | ○●○○○○ | 1-65535 | 1A/5mA | 50   | External CT ratio  |
| 17        | Under Frequency             | ○●○○○● | 0-800   | 0.1Hz  | 450  |  |
| 18        | Over Frequency              | ○●○○○● | 0-800   | 0.1Hz  | 550  |  |
| 19        | Under Voltage               | ○●○○○● | 0-5000  | 0.1V   | 2050 |  |
| 20        | Over Voltage                | ○●○○○● | 0-5000  | 0.1V   | 2450 |  |
| 21        | Over Current 1              | ○●○○○● | 0-65535 | 0.1A   | 450  | Generator pre-overload   |
| 22        | Over Current 2              | ○●○○○● | 0-65535 | 0.1A   | 500  | Generator overload   |
| 23        | Under Frequency Fault Delay | ○●○○○● | 0-65535 | 0.1S   | 20   | Generator output under frequency Stop Delay  |
| 24        | Over Frequency Fault Delay  | ○●○○○● | 0-65535 | 0.1S   | 5    | Generator output over frequency Stop Delay   |
| 25        | Under Voltage Fault Delay   | ○●○○○● | 0-65535 | 0.1S   | 20   | Generator output voltage low Stop Delay  |
| 26        | Over Voltage Fault Delay    | ○●○○○● | 0-65535 | 0.1S   | 5    | Generator output voltage high Stop Delay   |
| 27        | Over Current 1 Fault Delay  | ○●○○○● | 0-65535 | 0.1S   | 600  | Genset pre-overload delay timing   |
| 28        | Over Current 2 Fault Delay  | ○●○○○● | 0-65535 | 0.1S   | 50   | Genset overload delay timing   |
| 29        | Over Current 1 Stop Delay   | ○●○○○● | 0-65535 | 0.1S   | 300  | Genset pre-overload stop delay timing  |
| 30        | Over Current 2 Stop Delay   | ○●○○○● | 0-65535 | 0.1S   | 300  | Genset overload stop delay timing  |
| Battery   |                             |        |         |        |      |  |
| 31        | Under Voltage               | ○●●●●● | 0-400   | 0.1V   | 100  | Battery voltage under voltage alarm  |
| 32        | Over Voltage                | ●○○○○○ | 0-400   | 0.1V   | 180  | Battery voltage over voltage alarm   |

| Communication           |                              |        |         |       |      |  |
|-------------------------|------------------------------|--------|---------|-------|------|--|
| 33                      | Communication Address        | ●○○○○● | 0-32    | 1     | 1    | Communication address with the PC  |
| Maintenance             |                              |        |         |       |      |  |
| 34                      | Fuel filter maintenance time | ●○○○●○ | 0-65535 | 0.1Hr | 5000 | Engine Fuel filter replace countdown   |
| 35                      | Air filter maintenance time  | ●○○○●● | 0-65535 | 0.1Hr | 5000 | Engine Air filter replace countdown  |
| 36                      | Oil filter maintenance time  | ●○○●○○ | 0-65535 | 0.1Hr | 5000 | Engine Oil filter replace countdown  |
| Programmable Input Set  |                              |        |         |       |      |  |
| 37                      | Remote set                   | ●○○○●● | 0-5     | 1     | 4    | 0-Remote Start Normally Open<br>1-Remote Start Normally Closed<br>2-Remote Stop Normally Open<br>3-Remote Stop Normally Closed<br>4-Remote Start & Stop Normally Open<br>5-Remote Start & Stop Normally Closed |
| 38                      | Remote start delay           | ●○○○●○ | 0-65535 | 0.1s  | 50   | In remote mode, timing from give start signal to successfully start.   |
| 39                      | Remote Stop Delay            | ●○○○●● | 0-65535 | 0.1s  | 50   | In remote mode, timing from give Stop signal to successfully stop.   |
| 40                      | Remote start Times           | ●●○○○○ | 1-10    | 1     | 3    | In remote mode, start times in the normal range  |
| 41                      | Input 1 Type                 | ●●○○○● | 0-3     | 1     | 0    | 0-Warning Normally Open<br>1-Warning Normally Closed<br>2-Stop Normally Open<br>3-Stop Normally Closed   |
| 42                      | Input 1 Fault Delay          | ●○○○●○ | 0-65535 | 0.1s  | 0    | Set input 1 Fault Delay timing   |
| 43                      | Input 2Type                  | ●○○○●● | 0-3     | 1s    | 0    | 0-Warning Normally Open<br>1-Warning Normally Closed<br>2-Stop Normally Open<br>3-Stop Normally Closed   |
| 44                      | Input 2 Fault Delay          | ●○○○●○ | 0-65535 | 0.1s  | 0    | Set input 2 Fault Delay timing   |
| Programmable Output Set |                              |        |         |       |      |  |
| 45                      | Set Output 1                 | ●○○○●● | 0-16    | 1     | 0    | 0-Reserved<br>1-Genset Stop<br>2-Genset Preheat  |

|                     |                       |        |         |      |      |   |
|---------------------|-----------------------|--------|---------|------|------|---|
|                     |                       |        |         |      |      | 3-Genset Start<br>4-Genset Idle<br>5-Genset Running<br>6-Genset Electric Parameters Normal<br>7-System Warning Alarm<br>8-System Delay Stop Alarm<br>9-System Stop Alarm<br>10-System Alarm<br>11-Manual Mode<br>12-Remote Mode<br>13-Oil Filter Overtime<br>14-Fuel Filter Overtime<br>15-Air Filter Overtime<br>16-Start Failure  |
| 46                  | Set Output 2          | ●○○●●○ | 0-16    | 1    | 0    | 0-Reserved<br>1-Genset Stop<br>2-Genset Preheat<br>3-Genset Start<br>4-Genset Idle<br>5-Genset Running<br>6-Genset Electric Parameters Normal<br>7-System Warning Alarm<br>8-System Delay Stop Alarm<br>9-System Stop Alarm<br>10-System Alarm<br>11-Manual Mode<br>12-Remote Mode<br>13-Oil Filter Overtime<br>14-Fuel Filter Overtime<br>15-Air Filter Overtime<br>16-Start Failure |
| Idle                |                       |        |         |      |      |   |
| 47                  | Start idle Time       | ●○○●●● | 0-65535 | 0.1s | 0    | Timing from start idle running to rated RPM   |
| 48                  | Stop idle Time        | ●●○○○○ | 0-65535 | 0.1s | 0    | Timing from stop idle running to successfully stop.   |
| Password            |                       |        |         |      |      |   |
| 49                  | Password              | ●●○○○● | 0-65535 | 1    | 0310 | Set Password  |
| Generator Parameter |                       |        |         |      |      |   |
| 50                  | L1 Phase Voltage Gain | ●●○○●○ | 0-2047  | 1    | 1024 | Regulate the Gain to display the same L1 phase voltage on the controller with the actual voltage.   |

|    |                       |        |        |   |      |  |
|----|-----------------------|--------|--------|---|------|--|
| 51 | L2 Phase Voltage Gain | ●●○○●● | 0-2047 | 1 | 1024 | Regulate the Gain to display the same L2 phase voltage on the controller with the actual voltage.  |
| 52 | L3 Phase Voltage Gain | ●●○○○○ | 0-2047 | 1 | 1024 | Regulate the Gain to display the same L3 phase voltage on the controller with the actual voltage.  |
| 53 | L1 Phase current Gain | ●●○○●● | 0-2047 | 1 | 1024 | Regulate the Gain to display the same L1 phase current on the controller with the actual voltage.  |
| 54 | L2 Phase current Gain | ●●○○●● | 0-2047 | 1 | 1024 | Regulate the Gain to display the same L2 phase current on the controller with the actual voltage.  |
| 55 | L3 Phase current Gain | ●●○○●● | 0-2047 | 1 | 1024 | Regulate the Gain to display the same L3 phase current on the controller with the actual voltage.  |
| 56 | L12 Line Voltage Gain | ●●●○○○ | 0-2047 | 1 | 1024 | Regulate the Gain to display the same L12 Line Voltage on the controller with the actual voltage.  |
| 57 | L23 Line Voltage Gain | ●●●○○○ | 0-2047 | 1 | 1024 | Regulate the Gain to display the same L23 Line Voltage on the controller with the actual voltage.  |
| 58 | L31 Line Voltage Gain | ●●●○○○ | 0-2047 | 1 | 1024 | Regulate the Gain to display the same L312 Line Voltage on the controller with the actual voltage. |

## 8.2 Programmable output list

### 8.2.1 Remote set

Terminal “8” has “Remote” function; the function is only valid in “Remote mode”.

| No. | Contents                              | Note   |
|-----|---------------------------------------|--|
| 1   | 0—Remote start normally open          | Normally Open : in the default state, input signal open ( high potential);<br>input signal close ( low potential) is valid;<br>Normally Closed : in the default state, input signal close ( low potential);<br>input signal open ( high potential) is valid; |
| 2   | 1—Remote start normally closed        |  |
| 3   | 2—Remote Stop normally open           |  |
| 4   | 3—Remote Stop normally closed         |  |
| 5   | 4—Remote start & stop normally open   |  |
| 6   | 5—Remote start & stop normally closed |  |

#### 8.2.1.1 Remote start normally open

In the “Remote mode”, after Terminal “8” is closed ( low potential), genset start after Remote start delay (parameters can be setup). Terminal “8” open ( high potential), genset won’t stop.

#### 8.2.1.2 Remote start normally closed

In the “Remote mode”, after Terminal “8” is open ( high potential), genset start after remote start delay (parameters can be setup). Terminal “8” close ( low potential), genset won’t stop.

#### 8.2.1.3 Remote Stop normally open

In the “Remote mode”, After Terminal “8” is closed ( low potential), genset won’t start. Terminal “8” open ( high potential), genset stop after Remote Stop Delay (parameters can be setup).

#### 8.2.1.4 Remote Stop normally closed

In the “Remote mode”, After Terminal “8” is open ( high potential), genset won’t start. Terminal “8” close ( low potential), genset stop after Remote Stop Delay (parameters can be setup).

### 8.2.1.5 Remote start & stop normally open

In the “Remote mode”, After Terminal “8” is closed ( low potential), genset start after remote start delay (parameters can be setup). Terminal “8” open ( high potential), genset stop after Remote Stop Delay (parameters can be setup).

### 8.2.1.6 Remote start & stop normally closed

In the “Remote mode”, After Terminal “8” is open ( high potential), genset start after remote start delay (parameters can be setup). Terminal “8” close ( low potential), genset stop after Remote Stop Delay (parameters can be setup).

## 8.2.2 Set Input

Terminal “13” and Terminal “14” has “self-definition selective input” function ;  
 KP310\_1.00 controller has the following set input function.

| No. | Contents                         | Note  |
|-----|----------------------------------|---|
| 1   | <b>0-Warning Normally Open</b>   | Normally Open : in the default state, input signal open ( high potential);  |
| 2   | <b>1-Warning Normally Closed</b> | input signal close ( low potential) is valid;<br>Normally Closed : in the default state, input signal close ( low potential); |
| 3   | <b>2-Stop normally open</b>      | input signal open ( high potential) is valid;   |
| 4   | <b>3-Stop normally closed</b>    |   |

#### 8.2.2.1 Warning Normally Open

After Terminal is closed ( low potential), Warning alarm. Relevant set input faults LED light up.  
 After Terminal is open ( high potential), the Set Input faults is eliminated.

#### 8.2.2.2 Warning Normally Closed

After Terminal is open ( high potential), Warning alarm. Relevant set input faults LED light up.  
 After Terminal is closed ( low potential), the Set Input faults is eliminated.

#### 8.2.2.3 Stop normally open

After Terminal is closed ( low potential), confirmed by Set Input Fault Delay, stop the alarm immediately, relevant set input faults LED light up.



### 8.2.2.4 Stop normally closed

After Terminal is open ( high potential) ,confirmed by Set Input Fault Delay, stop the alarm immediately. Relevant set input faults LED light up.

## 8.3 Programmable output list



KP310\_1.00 controller has two terminals (terminal 17、18) to customers to set different parameters.

| No. | Contents                             | Note  |
|-----|--------------------------------------|---|
| 1   | 0—reserved                           | the function reserved                             |
| 2   | 1— genset Stop                       | Output when genset in the “Stop ” state           |
| 3   | 2— genset Preheat                    | Output when genset in the “ Preheat ” state       |
| 4   | 3— genset start                      | Output when genset in the “start ” state          |
| 5   | 4— genset idle                       | Output when genset in the “ idle ” state          |
| 6   | 5— genset running                    | Output when genset in the “ normal running” state |
| 7   | 6— genset electric parameters normal | Output when genset voltage, frequency is normal   |
| 8   | 7—system Warning alarm               | Output when system Warning alarm                  |
| 9   | 8—system delay stop alarm            | Output when system delay stop alarm               |
| 10  | 9—system Stop alarm                  | Output when system delay alarm                    |
| 11  | 10—system alarm                      | Output when system alarm                          |
| 12  | 11—manual mode                       | Output when system in the “manual mode ”          |
| 13  | 12—Remote mode                       | Output when system in the “Remote mode ”          |
| 14  | 13—Oil filter overtime               | Output when Oil filter overtime alarm             |
| 15  | 14—Fuel filter overtime              | Output when Fuel filter overtime alarm            |
| 16  | 15—Air filter overtime               | Output when Air filter overtime alarm             |
| 17  | 16—start failure                     | Output when genset start failure                  |

□Note: if Set Output 1 or Set Output 2 is set as “**4— genset idle**”, start idle Time or Stop idle Time can't be 0, otherwise there will be no idle output.

## 9. Commission

Before commission, please check as follows:

- 1、 Check all connections and wires;
- 2、 Right connection with batteries;
- 3、 Right connection of Emergency Stop button with battery;
- 4、 Take proper measures to prevent engine from starting such as dismantle fuel valve connections, then connect with battery, select manual mode.
- 5、 Press  (start ) button, genset will start ; start failure alarms, press  (Stop ) to recover the controller;
- 6、 Recover Engine to start (such as recover fuel valve connections) , press  (start ) button , genset will start , if everything is OK, genset will be in the idle state for a while (if idle running is available) then genset will run normally. In this period, check if everything is OK, for example voltage, frequency. If there are some abnormal situations, stop genset, check the connection refer to the Manual;
- 7、 Please contact with us if you need help..

## 10. Applications

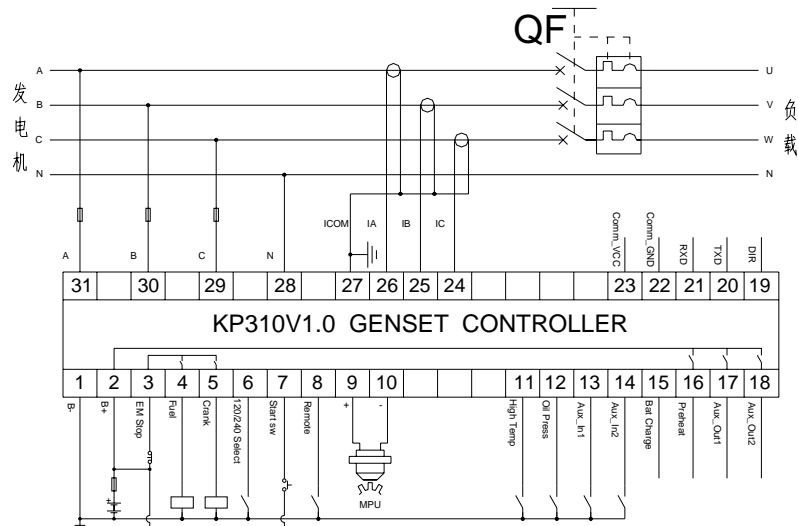

# 11. Installations

KP310V1.0 controller is panel mounting. Dimensions are as follows:

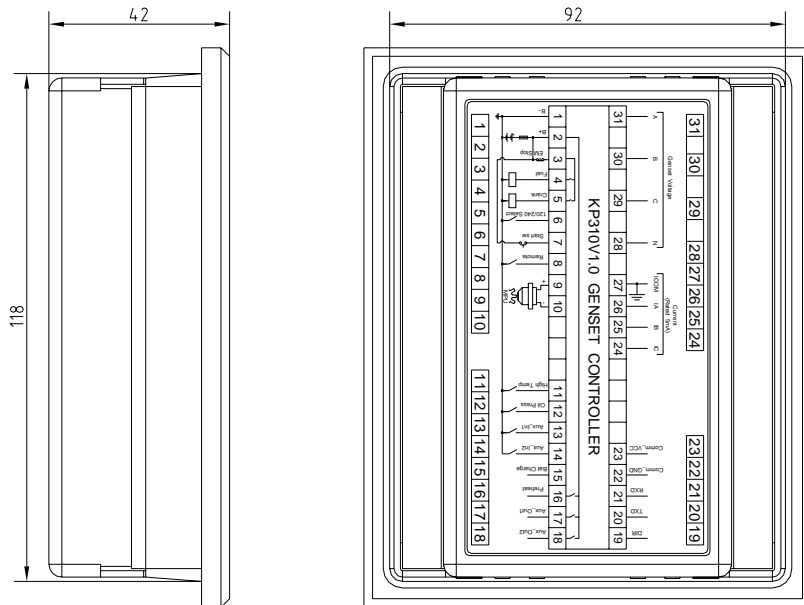

## 12. Trouble shooting

| Troubles                                 | Solutions  |
|--|--|
| Controller no electricity                | Check batteries<br>Check controller connections<br>Check DC fuse   |
| genset Stop                              | Check if water temperature is over high<br>Check AC Generator voltage<br>Check DC fuse   |
| controller emergency stop                | Check if emergency function is OK<br>Check connections of batteries with emergency stop button<br>Check if circuits is open              |
| Low oil pressure alarm after start       | Check oil pressure sensor and connections  |
| High water temperature alarm after start | Check water temperature sensor and connections   |
| Alarm & Stop during running              | Check relevant connections<br>Check Set Input parameters   |
| start failure                            | Check fuel pipe and connections<br>Check batteries<br>Check RPM sensor and connections<br>Refer to the Engine's Manual                   |
| No start signals                         | Check start motor and connections<br>Check batteries   |
| RS232 failure                            | Check the connections<br>Check if COM port is right setup<br>Check connections between RS232 TXD with RXD<br>Check PC communication port |

## 13. Serial Communication

This communication protocol applies to serial communications between controller and PC, or between remote controller and display module.

PC and controller meet standard industrial communication protocol in Host and Slave mode. PC (the Host) sends enquiries, controller (the slave) reply them.

### 13.1 Physical Layer of Communication Protocol

Comm port: EIA/TIA-232-E  
 Comm mode: asynchronous  
 Comm speed: 9600bps  
 Parity check: no  
 Start bit: 1  
 Data bit: 8  
 Stop bit: 1  
 Data period: <5ms  
 Frame-frame period: >100ms  
 Comm timeout: 200ms

|       |      |      |      |      |      |      |      |      |       |
|-------|------|------|------|------|------|------|------|------|-------|
| Bit1  | Bit2 | Bit3 | Bit4 | Bit5 | Bit6 | Bit7 | Bit8 | Bit9 | Bit10 |
| Start | D0   | D1   | D2   | D3   | D4   | D5   | D6   | D7   | Stop  |

### 13.2 Enquiry/ Response Period

The host starts enquiring actively, and the slave responds passively as following:

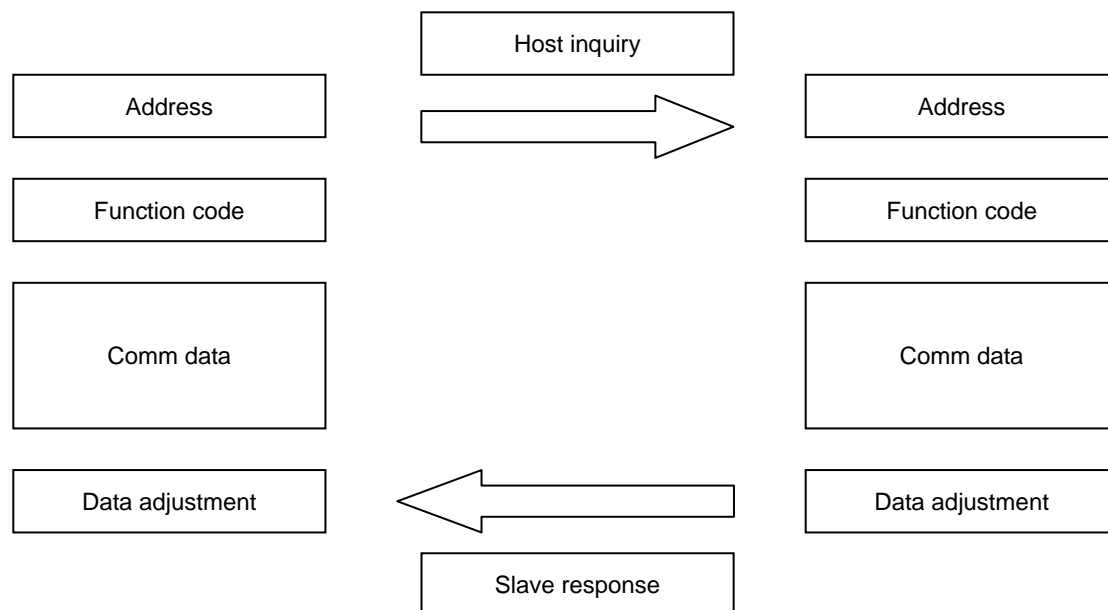

## 13.3 Comm RTU

This communication protocol uses RTU (remote terminals communication unit ) mode, namely binary.

| Address field | Function field | Data field  |        | Data adjustment field |
|---------------|----------------|-------------|--------|-----------------------|
| Slave address | Function code  | Data length | Data   | CRC16                 |
| 2Bytes        | 2Bytes         | 2Byte       | nBytes | 2Bytes                |

### 13.3.1 Address field

Definition of address field is the only address in MODBUS.

This communication protocol applies to one-to-one communication between PC and controller.

Low byte is before the high byte.

### 13.3.2 Function field

Function code is the Host operation code and reply code from Host..

### 13.3.3 Data field

Value is the actual bytes of data (3.2)

Data type: 2Byte

### 13.3.4 Data CRC field

Data check uses CRC16-CCITT as standard to check all data in MODBUS except data in check field. Low byte stands after high byte.

The host machine sends messages to MODBUS and the slave produces CRC16 code to respond; the host and slave have to calculate CRC16 code according to CRC16 multinomial.

CRC16-CCITT produces multinomial:  $X^{16}+X^{12}+X^5+1$ , CRC16-CCITT more details in appendix 1 & 2.

## Appendix 1 CRC16-CCITT Sheet

```
unsigned int CRC16CCITT[]=  
{  
0x0000, 0x1021, 0x2042, 0x3063, 0x4084, 0x50a5, 0x60c6, 0x70e7,  
0x8108, 0x9129, 0xa14a, 0xb16b, 0xc18c, 0xd1ad, 0xe1ce, 0xf1ef,  
0x1231, 0x0210, 0x3273, 0x2252, 0x52b5, 0x4294, 0x72f7, 0x62d6,  
0x9339, 0x8318, 0xb37b, 0xa35a, 0xd3bd, 0xc39c, 0xf3ff, 0xe3de,  
0x2462, 0x3443, 0x0420, 0x1401, 0x64e6, 0x74c7, 0x44a4, 0x5485,  
0xa56a, 0xb54b, 0x8528, 0x9509, 0xe5ee, 0xf5cf, 0xc5ac, 0xd58d,  
0x3653, 0x2672, 0x1611, 0x0630, 0x76d7, 0x66f6, 0x5695, 0x46b4,  
0xb75b, 0xa77a, 0x9719, 0x8738, 0xf7df, 0xe7fe, 0xd79d, 0xc7bc,  
0x48c4, 0x58e5, 0x6886, 0x78a7, 0x0840, 0x1861, 0x2802, 0x3823,  
0xc9cc, 0xd9ed, 0xe98e, 0xf9af, 0x8948, 0x9969, 0xa90a, 0xb92b,  
0x5af5, 0x4ad4, 0x7ab7, 0x6a96, 0x1a71, 0x0a50, 0x3a33, 0x2a12,  
0xdbfd, 0xcdbc, 0xfbbf, 0xeb9e, 0x9b79, 0x8b58, 0xbb3b, 0xab1a,  
0x6ca6, 0x7c87, 0x4ce4, 0x5cc5, 0x2c22, 0x3c03, 0x0c60, 0x1c41,  
0xedae, 0xfd8f, 0xcdec, 0xddcd, 0xad2a, 0xbd0b, 0x8d68, 0x9d49,  
0x7e97, 0x6eb6, 0x5ed5, 0x4ef4, 0x3e13, 0x2e32, 0x1e51, 0x0e70,  
0xff9f, 0xefbe, 0xdfdd, 0xcffc, 0xbf1b, 0xaf3a, 0x9f59, 0x8f78,  
0x9188, 0x81a9, 0xb1ca, 0xa1eb, 0xd10c, 0xc12d, 0xf14e, 0xe16f,  
0x1080, 0x00a1, 0x30c2, 0x20e3, 0x5004, 0x4025, 0x7046, 0x6067,  
0x83b9, 0x9398, 0xa3fb, 0xb3da, 0xc33d, 0xd31c, 0xe37f, 0xf35e,  
0x02b1, 0x1290, 0x22f3, 0x32d2, 0x4235, 0x5214, 0x6277, 0x7256,  
0xb5ea, 0xa5cb, 0x95a8, 0x8589, 0xf56e, 0xe54f, 0xd52c, 0xc50d,  
0x34e2, 0x24c3, 0x14a0, 0x0481, 0x7466, 0x6447, 0x5424, 0x4405,  
0xa7db, 0xb7fa, 0x8799, 0x97b8, 0xe75f, 0xf77e, 0xc71d, 0xd73c,  
0x26d3, 0x36f2, 0x0691, 0x16b0, 0x6657, 0x7676, 0x4615, 0x5634,  
0xd94c, 0xc96d, 0xf90e, 0xe92f, 0x99c8, 0x89e9, 0xb98a, 0xa9ab,  
0x5844, 0x4865, 0x7806, 0x6827, 0x18c0, 0x08e1, 0x3882, 0x28a3,  
0xcb7d, 0xdb5c, 0xeb3f, 0xfb1e, 0x8bf9, 0x9bd8, 0xabbb, 0xbb9a,  
0x4a75, 0x5a54, 0x6a37, 0x7a16, 0x0af1, 0x1ad0, 0x2ab3, 0x3a92,  
0xfd2e, 0xed0f, 0xdd6c, 0xcd4d, 0xbdaa, 0xad8b, 0x9de8, 0x8dc9,  
0x7c26, 0x6c07, 0x5c64, 0x4c45, 0x3ca2, 0x2c83, 0x1ce0, 0x0cc1,  
0xef1f, 0xff3e, 0xcf5d, 0xdf7c, 0xaf9b, 0xbfba, 0x8fd9, 0x9ff8,  
0x6e17, 0x7e36, 0x4e55, 0x5e74, 0x2e93, 0x3eb2, 0x0ed1, 0x1ef0  
};
```

## Appendix 2 CRC16-CCITT

```
/******  
Function: generate CRC16CCITT code  
Input: p = mouse cursor points to first byte  
DataLen =data length  
Output: CRC16CCITT  
*****/  
Unsigned int CRC16CCITT (unsigned char *p, unsigned int DataLen)  
{  
    Unsigned int crc16=0;  
    Unsigned int i;  
    Unsigned char b;  
    for (i=0;i<DataLen;i++)  
    {  
        b=(unsigned char)(crc16>>8);  
        crc16<<=8;  
        crc16^= CRC16CCITT [b^*p];  
        p++;  
    }  
    return crc16;  
}
```



# Appendix 3 Wiring Diagram

## 1) 3-Phase 4-Line

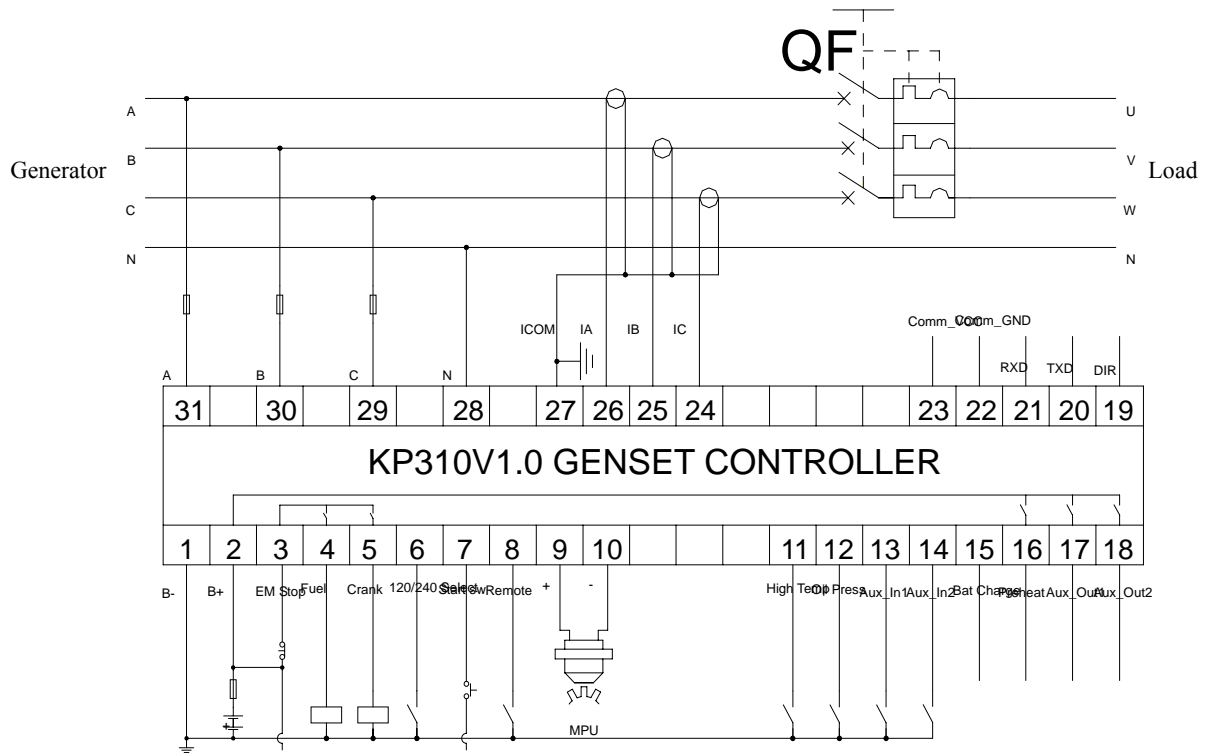

## 2) 3-Phase 3-Line

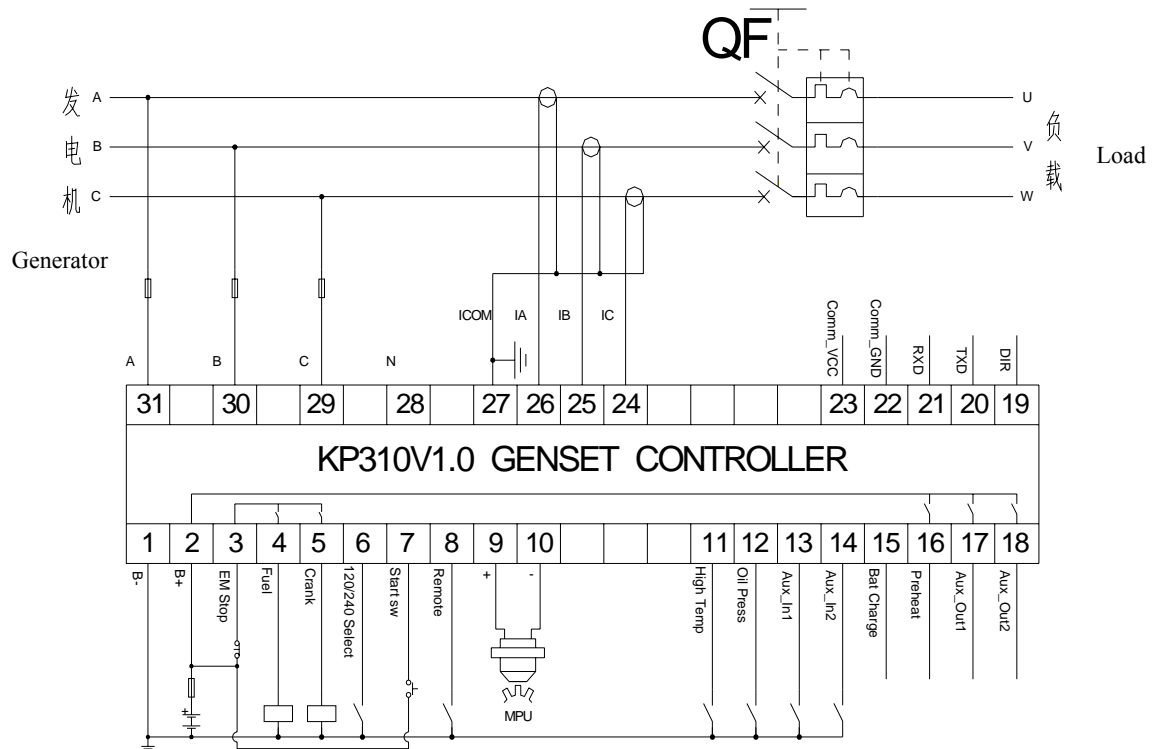

### 3) 1-Phase 2-Line

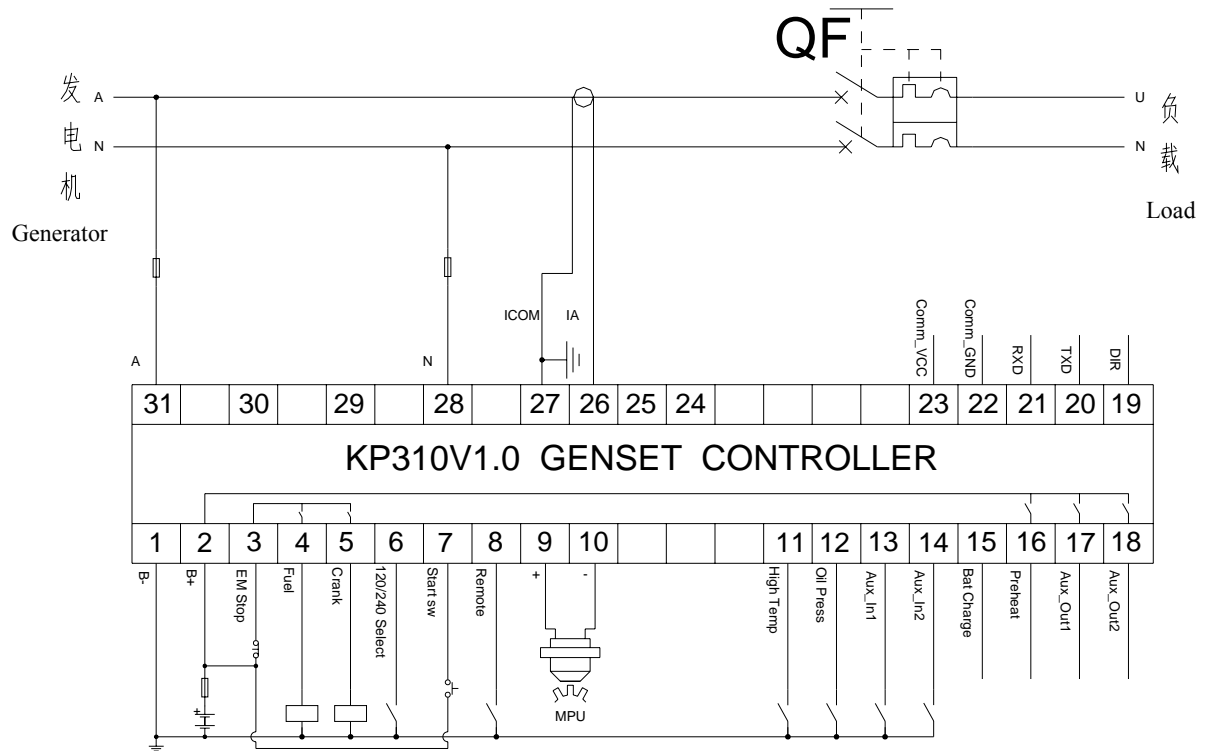

### 4) 2-Phase 3-Line

