

The clarification of notation used within this manual:



WARNING

WARNING:

A **WARNING** indicates a potentially hazardous situation which, if not avoided, could result in death, serious personal injury or property damage.



CAUTION

CAUTION:



A **CAUTION** indicates a potentially hazardous situation which, if not avoided, could result in damage to equipment or property.



NOTE:

A **NOTE** provides other helpful information that does not fall under the warning or caution categories.

This manual only suitable for ASM18G generator automatic controller, user must read this manual carefully first.

 WARNING	<p>WARNING: Read this entire manual pertaining to the work to be performed before installing, operating, or servicing this controller. Practice all plant and safety instructions and precautions. Failure to follow instructions can cause personal injury and/or property damage.</p> <p>The engine or other type of prime mover should be equipped with an overspeed shutdown device to protect against runaway or damage to the prime mover with possible personal injury, loss of life, or property damage.</p> <p>The overspeed shutdown device must be totally independent of the prime mover control system. An overtemperature or overpressure shutdown device may also be needed for safety, as appropriate.</p>
 CAUTION	<p>CAUTION—BATTERY CHARGING To prevent damage to a controller that uses an alternator or battery-charging device, make sure the charging device is turned off before disconnecting the battery from the System.</p> <p>Controllers contain static-sensitive parts. Observe the following precautions to prevent damage to these parts: Do not disassemble the rear back of controller and touch the components or conductors on a printed circuit board.</p>

1. Description

ASM18G is an auto control and protection module of generator. The control modes of manual or auto are selectable by buttons on panel. Manual starts or stops Genset under manual mode by buttons on panel. Auto starts or stops Genset under auto mode by remote switch input signal. The module is adopted LCD, which displays running status and operating parameters of generator. The main characteristics as following:

- The core adopts MPU.
- Flexible configure running parameters via buttons and LCD on panel.
- Measure and display parameters, such as frequency and voltage for generator, battery voltage, oil pressure, oil level, coolant temperature and running hours for engine.
- Has five relays control output, others can be defined by user except the outputs of fuel and start control are fixed.
- 3 channels for switch input, all can be defined by user.
- 3 channels analog input for coolant temperature, oil pressure and oil level sensor .
- Internal kinds of P-sensor and T-sensor for user choice.
- Optional internal communication interface can be used to configure parameters via PC.
- All connections are connected by pin-like and locked up terminal, easier and more convenient to connect, move, maintain and replace the device.

2. The Outline Dimensional Drawings and Wirings

2.1 Following Details:

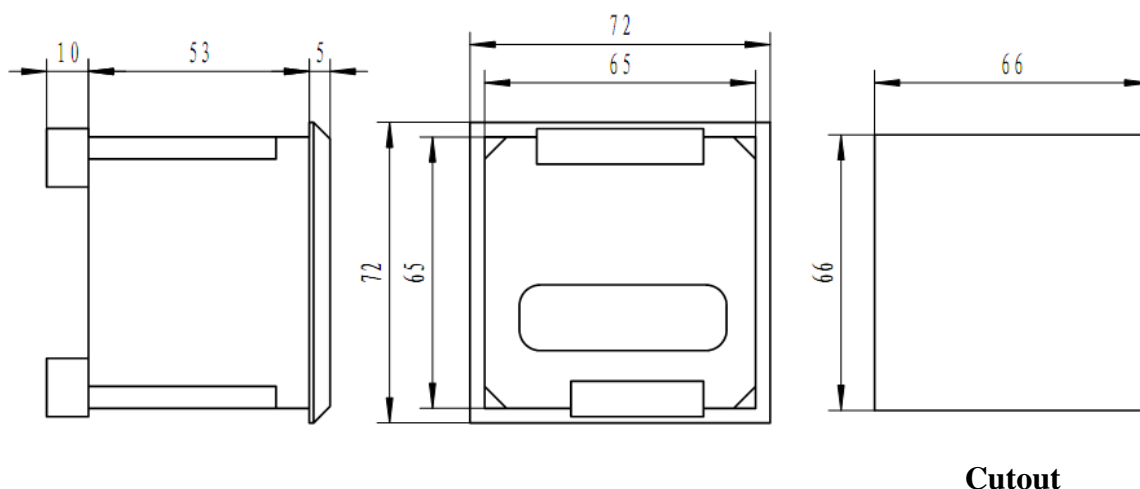

Fig. 1 Outline and installing dimension

2.2 Connecting Terminals:

Pin no.	Function Description	Signal	Dim
1	Plant supply {+}	(8-35Vdc continuous)	1mm ²
2	Plant supply {-}		1mm ²
3	Start relay output	N.O. contact, 3A/30Vdc	1mm ²
4	Output fuel solenoid relay	N.O. contact, 3A/30Vdc	1mm ²
5	Configurable output 1	N.O. contact, 3A/30Vdc	1mm ²
6	Configurable output 2	N.O. contact, 3A/30Vdc	1mm ²
7	Configurable output 3	N.O. contact, 3A/30Vdc	1mm ²
8	Charger excitation power output	if not used, do not connect to negative	1mm ²

9	Coolant temperature sensor		1mm ²
10	Oil pressure sensor		1mm ²
11	Fuel level sensor		1mm ²
12	Configurable switch input signal 1	low level is active	1mm ²
13	Configurable switch input signal 2	low level is active	1mm ²
14	Configurable switch input signal 3	low level is active	1mm ²
15	Phase voltage input	0-300Vac	1mm ²
16	Neutral		1mm ²

CAUTION:

When sensor is used, can increase the cross section area of cable base on the practical condition, so that to reduce the cable resistance that from controller to engine, to make sure the accuracy of measured values both for oil pressure and temperature.

CAUTION
CAUTION:

If not use pin no. "8" do not connect to negative.

2.3 Typical Wiring Diagram

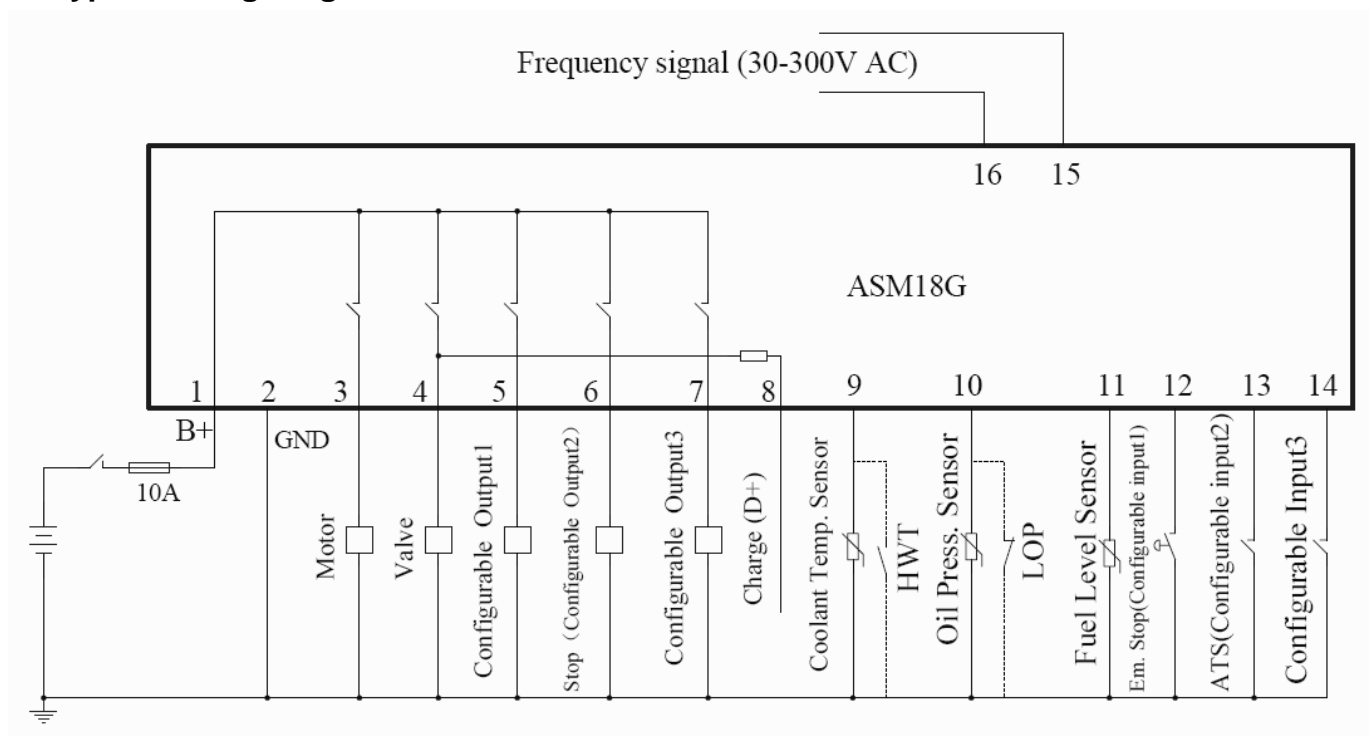





















Fig. 2 Typical Wiring Diagram











3. Operation Panel

The whole operation panel includes 2 sections: LCD displays measuring parameters, control buttons and select buttons for control modes. LCD cycle displays different measuring parameters. When failure occurs LCD displays corresponding sign. LCD has background-light function so that operator can clearly read information whenever at day or night. After pressing any buttons the background-light will turn on and auto turn off in a certain time. LCD display and its control buttons provide a friendly operation interface for operator, which makes operator conveniently read information and set running parameter.

3.1 Control buttons and LED

Function Description	
	<p>Enter parameter set status/Enter parameter modify/Select modify digit/Confirm modification/Exit parameter set status/Select display item</p> <p>1. Press  2s in normal status,controller enter parameter set status,LCD display parameter code and "SET" icon , press  and  select the parameter want to modify. Press ,controller enter parameter modify status, LCD display the parameter value ,and the unit's digit of parameter is flash, by this press  and  to modify the the unit's digit of parameter, press  to select other digits to modify, and the selected digits is flash. If the highest digit is selected and flash,press ,controller exit parameter modify status and Confirm modification, LCD display next parameter code . In parameter set status, press  2s,controller exit parameter set status to normal status .</p> <p>2. In normal status, press ,controller display next item .</p>
	<p>AUTO/Next parameter/Parameter value increase</p> <p>1. In normal status,press  2S, controller enter automatic status, LCD display "AUTO" icon. Of the moment,if remote start input signal is active, controller will start generator set ,and if remote start input signal is not active, controller will stop the generator set .</p> <p>2. In parameter set status: a. Select next Parameter. b. The flash digit of parameter value increase .</p>
	<p>Manual / Front parameter / Parameter value decrease</p> <p>1. In normal status, press  2S, LCD display  icon, controller start the generator set .</p> <p>2. In parameter set status: a. Select front Parameter. b. The flash digit of parameter value decrease .</p>
	<p>Stop / Reset</p> <p>1. In normal status, press  2S, controller stop the generator set .</p> <p>2. If generator set is failure, press  will reset the failure status .</p>

3.2 LCD Display

Icon	Meanings
BAR	Oil pressure, unit is BAR
PSI	Oil pressure, unit is PSI
°C	Coolant temperature, unit is °C
° F	Coolant temperature, unit is ° F
SET	Controller is in parameter set status
V~	Generator voltage, unit is V
V.	Battery voltage, unit is V
HZ	Generator frequency, unit is HZ
h	Generator running time, unit is hour
%	Fuel level, percent
RPM	Engine speed, unit is RPM
	Manual status
AUTO	Automatic status
LOW	Value is low , flash
HIGH	Value is high, flash
	Failure indication Warning, flash Failure and stop, display
	High Temperature: if controller detects that engine coolant temperature has exceeded the high coolant temperature alarm value or temperature switch is closing, engine stop immediately. LCD displays high temperature icon.
	Low Oil Pressure: if controller detects that the oil pressure level still falls below oil pressure alarm value or oil pressure switch is closing after the safety-on timer has expired, engine stop immediately. LCD displays low oil pressure icon.
	Battery charge failure
	Overspeed: if controller detects that engine speed exceeds the overspeed alarm value, engine stop immediately. LCD displays overspeed icon.
	Auxiliary Failure: define a configurable switch as failure input, when the input signal is active. LCD displays Aux. warning icon.
	Emergency Stop: define a configurable switch as emergency stop input, when the input signal is active, controller immediately stop. LCD displays “emergency stop” icon.
	Fail to Stop: if engine does not stop after the stop delay expires. LCD displays “fail to stop” icon.
	Fail to Start: if engine does not fire after the preset number of crank attempts has been made, means fail to start. LCD displays “fail to start” icon.
Stop	Generator set is stopping , flash
	Generator set is cranking, flash

4. Installation Guide

4.1 The dimensional drawing of install cutout on panel, shown as Fig.1 .









The controller is fixed by 2 special mounting fittings. The shock-proof equipment must be installed, if the enclosure that installed on controller is directly installed on Genset body or other heavy vibrant device. A readily accessible disconnect device shall be incorporated external to the equipment;

4.2 Please see Fig. 2 Typical Wiring Diagram for wiring connecting.

5. Control and Operation Instruction

The controller has 3 kinds of control mode: AUTO mode ,MAN mode and parameter set mode .

5.1 Operation Mode Setting:

Operation	
Press  2S, LCD display "AUTO" icon, controller is running in AUTO mode.	
Press  2S, LCD display  icon and  icon flash,controller is running in MAN mode, and start the generator set .	
Press  2s, LCD display  icon and "Stop" icon flash, controller is running in MAN mode , and stop the generator set .	
In AUTO or MAN mode, press  2S, LCD display "SET" icon, controller enter parameter set mode. In parameter set mode,press  2s, LCD display  icon, controller will confirm the parameter modify and come back to MAN mode .	

5.2 Automatic Control Process:

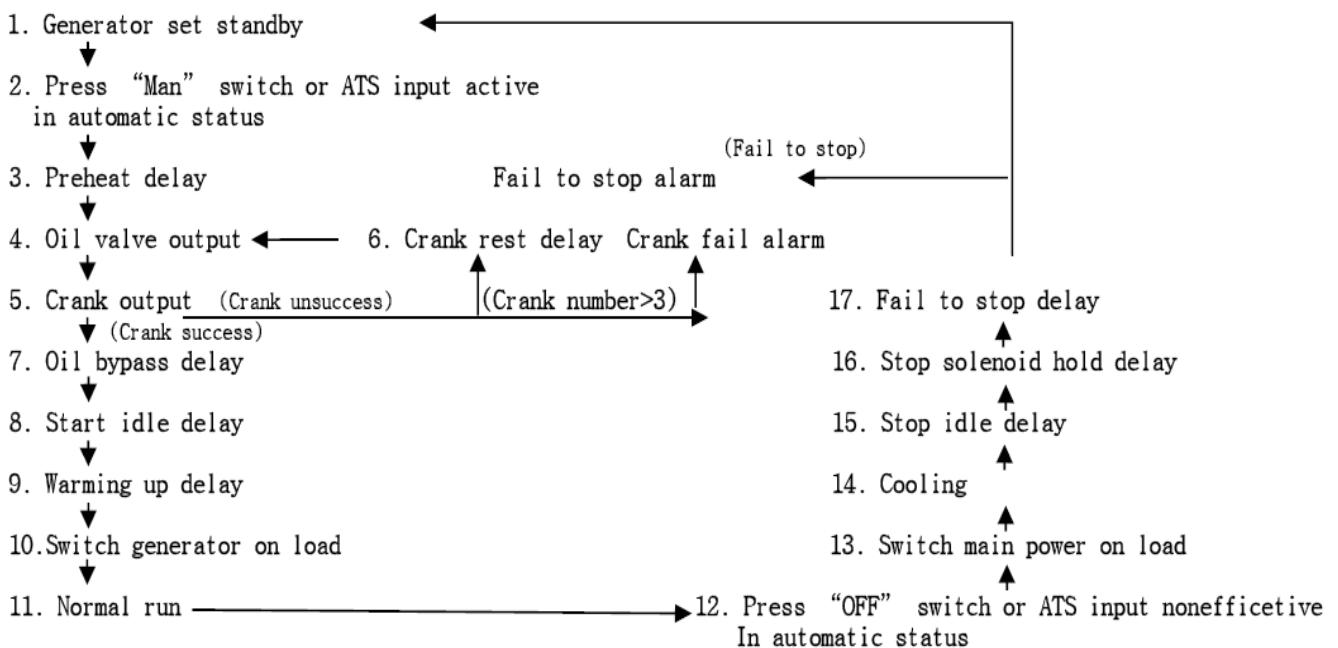

5.3 Idle function:

When one of the configurable outputs is defined as **Idle**, controller has idle control function immediately.

- Generator is not start, "Idle output" and "Rise speed output" is open .
- In generator cranking, "Idle output" is close and "Rise speed output" is open .
- Generator start succeed,after "Start idle delay time", "Idle output" is open and "Rise speed output" is close .
- Generator stopping, in the "Stop idle delay time" period,"Idle output" is close and "Rise speed output" is open .

5.4 Preheat function:

When one of the configurable outputs is defined as **Preheat**, controller obtains preheat control function immediately.

Controller has 3 optional preheat control modes:

Mode 1 — during preheat time, preheat relay making output.

Mode 2 — during preheat time, preheat relay making output until successfully ignition.

Mode 3 — during preheat time, preheat relay making output until safety-on delay expired.

No matter setting at which mode, during crank attempt the preheat relay will not making output.

6. Measure and Display Data

The AC phase voltage of generator **V~**

Generator frequency **Hz**

Engine speed **RPM** (signal from generator frequency)

Battery voltage **V₋**

Engine running hours **h**

Engine coolant temperature **°C /F** (signal from engine T-sensor)

Engine oil pressure **BAR /PSI** (signal from engine P-sensor)

Engine fuel level **percent**

7. Warning and Shutdown Alarm
7.1 Warning

(NOTE: Warns are non-critical failure conditions and do not affect the operation of the generator system, they serve to draw the operators' attention to an undesirable condition and remove it to make sure system continuous running. When warns occur, the status indicator light flash, but failure will not be locked and the unit will not shutdown. Once failure removed warning indicator auto turn off.)

Warning discription
<p>Fail to Charge: if controller detects that voltage has fallen below the “low battery warning value” from the excitation contact of auxiliary AC charger after the safety-on timer has expired,</p> <p>LCD  icon flash.</p>
<p>Battery Low Voltage: if controller detects that battery voltage has fallen below the “low battery warning value”, LCD "LOW" icon flash.</p>
<p>Battery High Voltage: if controller detects that battery voltage has exceeded the “high battery warning value”, LCD "HIGH" icon flash.</p>
<p>Low Oil Pressure: if controller detects that the engine oil pressure has fallen below the “low</p>

oil pressure warning value” after the safety-on timer has expired, LCD "LOW" icon flash.
High Temperature: if controller detects that engine coolant temperature has exceeded the “high coolant temperature warning value”, LCD "HIGH" icon flash.
Overspeed: if engine speed exceeds the“overspeed warning value”,LCD "HIGH" icon flash.
Underspeed: if engine speed falls below the“underspeed warning value” after the safety-on timer has expired, LCD "LOW" icon flash.
Low fuel level: if fuel level falls below the“Low fuel level warning value” expired, LCD "LOW" icon flash.
High Voltage: if controller detects that the voltage of generator any phase output has exceeded the “high voltage warning value” after the safety-on timer has expired,LCD "HIGH" icon flash.
Low Voltage: if controller detects that the voltage of generator any phase output has fallen below the “low voltage warning value” after the safety-on timer has expired, LCD "LOW" icon flash.

Note:









To make warnings of “low oil pressure” ,“high coolant temperature” and "low fuel level " active, must use P-sensor and T-sensor, F-sensor,when only use oil pressure switch and temperature switch, both warnings inactive.







Caution:

Under the period of safety-on delay, some warnings are inactive,the safety-on time must be carefully and properly set to make Genset has full protection.

7.2 Shutdown Alarm

(**NOTE:** shutdown failures immediately lock system and stop generator, it only can operate controller again after removing failures and press rest button to unlock)

Failures Description
Fail to Start: if engine does not fire after the preset number of crank attempts has been made,means fail to start, LCD displays  and  icon.
Fail to Stop: if engine does not stop after the stop delay expires, LCD displays  and  icon.
Emergency Stop: define a configurable switch as emergency stop input, when the input signal is active, controller immediately stop all relay control output except alarm, LCD displays  and  icon.
Low Oil Pressure: if controller detects that the oil pressure level still falls below oil pressure alarm value or oil pressure switch is closing after the safety-on timer has expired, engine stop immediately, LCD display  and  icon.
High Temperature: if controller detects that engine coolant temperature has exceeded the high coolant temperature alarm value or temperature switch is closing, engine stop

immediately, LCD displays  and  icon.
Overspeed: if controller detects that engine speed exceeds the overspeed alarm value, engine stop immediately, LCD displays  and  icon.
Auxiliary Failure: define a configurable switch as failure input, when the input signal is active, LCD displays  and  icon.

Note:

- Engine speed signal is from generator output voltage frequency, is used for control and failure protection parameters, to the convenience of user, some data expressed by RPM, $RPM=HZ*60/\text{pair of poles}$.
- The generator occur failure during its operating: after occur high temperature, low oil pressure and overspeed stop immediately no delay; when occur low oil pressure during coolant delay, only set idle delay at 0 (means on idle function) to make protection, or inactive.

Caution:

Under the period of safety-on delay, the protection of low oil pressure failure is inactive, to avoid non oil start engine, must make sure the oil is normal and the safety-on time shall be carefully and properly set for the first commissioning.

8. Parameters Setting

8.1 System Parameters:

Code	Items	Range	Preset	Description
PASS	Password		1111	Parameters set password
P1.01	Begin control mode	0-1	0	0- MAN mode 1- AUTO mode
P1.02	oil pressure units	0-2	2	0-Display BAR 1-Display PSI 2- All
P1.03	temperature units	0-2	2	0-Display °C 1-Display ° F 2-All
P1.04	communication address	1-255	1	
P1.05	page scroll time	0-10S	5	0- not used

8.2 Generator Parameters:

Code	Items	Range	Preset	Description
P2.01	pair of poles	1-4	2	pair of generator poles
P2.02	V low warning	0-300V	196V	
P2.03	V low failure	0-300V	0V	
P2.04	V high warning	0-1000V	264V	
P2.05	V high failure	0-1000V	1000V	
P2.06	Failure delay	1-6000S	5S	

8.3 Engine Parameters:

Code	Items	Range	Preset	Description
P3.01	T-sensor type	0-4	2	0- not used 1-configurable(base on sensor Data)

				2- EQ153 3- VDO 4- KDS
P3.02	P-sensor type	0-3	2	0- not used 1-configurable(base on sensor data) 2- YG2221 3- VDO
P3.03	Fuel-sensor type	0-2	2	0- not used 1- configurable(base on sensor data) 2- KZ
P3.04	start delay	0-6000S	5S	
P3.05	crank attempt	1-10	3	
P3.06	crank time	1-60S	5S	
P3.07	crank rest	5-6000S	10S	
P3.08	crank disconnect frequency	10-30Hz	15Hz	
P3.09	crank disconnect by oil pressure function	0-1	1	0-Disable 1-Enable
P3.10	crank disconnect oil pressure	0.5-15 BAR	2.0BAR	
P3.11	preheat delay	0-6000S	0S	
P3.12	preheat mode	1-3	1	
P3.13	start idle delay	0-6000S	0S	
P3.14	Stop idle delay	0-6000S	0S	
P3.15	safety on delay	1-6000S	10S	
P3.16	Engine warming delay	1-6000S	5S	
P3.17	cooling delay	1-6000S	10S	
P3.18	Stop output delay	1-6000S	10S	
P3.19	fail to stop delay	1-6000S	5S	
P3.20	Stop delay	1-6000S	5S	

8.4 Warning/Failure value set

Code	Items	Range	Preset	Description
P4.01	Under speed warning	0-6000RPM	1440	
P4.02	Over speed warning	300-6000RPM	1600	
P4.03	Under speed failure	0-6000RPM	0	
P4.04	Over speed failure	300-6000RPM	1710	
P4.05	Low oil-press failure	0-15 BAR	1.5BAR	
P4.06	low oil-press warning	0-15 BAR	2.2BAR	

P4.07	high temp warning	70-130°C	95°C	
P4.08	high temp failure	70-130°C	98°C	
P4.09	Low fuel warning	0-100%	25%	
P4.10	Low battery warning	0-25V	8.0V	
P4.11	High battery warning	1-35V	28V	
P4.12	charge V warning	1-25V	8.0V	
P4.13	Over speed failure delay	0-6000S	3S	
P4.14	Under speed Failure delay	0-6000S	3S	
P4.15	high temp failure delay	0-6000S	2S	
P4.16	Low oil-press failure delay	0-6000S	2S	

8.5 Input and Output Setting

Code	Items	Range	Preset	Description
P5.01	Configurable input1	0-6	3	0-not used 1-close for low oil pressure 2-close for high temperature 3-emergency stop 4-remote start 5-failure (active immediately) 6-failure(active after safety-on delay)
P5.02	Configurable input2	0-6	2	0-not used 1-close for low oil pressure 2-close for high temperature 3-emergency stop 4-remote start 5-failure (active immediately) 6-failure(active after safety-on delay)
P5.03	Configurable input3	0-6	1	0-not used 1-close for low oil pressure 2-close for high temperature 3-emergency stop 4-remote start 5-failure (active immediately) 6-failure(active after safety-on delay)
P5.04	input 1 delay	0-6000S	2S	
P5.05	input 2 delay	0-6000S	2S	
P5.06	input 3 delay	0-6000S	2S	
P5.07	Configurable relay 1	0-7	1	0-Not used 1-Alarm 2-Idle 3-Speed up 4-Preheat 5-Generator on 6-Stop output

P5.08	Configurable relay 2	0-7	6	0-Not used 1-Alarm 2-Idle 3-Speed up 4-Preheat 5-Generator on 6-Stop output
P5.09	Configurable relay 3	0-7	3	0-Not used 1-Alarm 2-Idle 3-Speed up 4-Preheat 5-Generator on 6-Stop output

Note:

Define one of the configurable outputs as **Speed Up**, after controller detects that engine is successfully crank, speed up relay making output; if has idle function, then speed up relay making output after idle delay expired.

8.6 Calibration Menu

Code	Items	Range	Preset	Description
P6.01	Generator voltage	90-110%	100	
P6.02	Oil pressure	90-110%	100	
P6.03	Coolant Temperature	90-110%	100	
P6.04	Fuel level	90-110%	100	
P6.05	Battery voltage	90-110%	100	

9. Preparation before Start the Controller

9.1 Make sure controller is fixed well and its install ambient meet requirements.

9.2 Confirm all wiring connections of controller are meet electric specification and corresponding to "Fig. 2 typical wiring diagram". Especially need confirm DC supply source has added fusing element to protect, and correct polarity. Otherwise, it maybe damage controller.

9.3 We recommend mounting "E- stop" button in external, connecting E-stop signal input terminal to the N. O. contact of "E- stop" button, and another terminal of contact connected to the negative of battery source.

9.4 Switch on DC plant supply, make sure the preset parameter meet practical condition, such as P-sensor mode, T-sensor mode, etc.

10. Troubleshooting

Failure	Phenomenon	Failure Eliminate
Genset no crank	No crank attempt either in "MAN" mode press "START" button or in "AUTO" mode the remote start signal is active.	<ol style="list-style-type: none"> 1. Check LCD display to confirm has failure display or not. 2. Check DC voltage on controller no. "1" "2" terminal, if no voltage, check related circuitry fuse. Such as low voltage, use charger charging battery, restart after battery fully charging. 3. Check DC voltage on controller no. "3" terminal when crank, if no voltage, need change controller. 4. Check starting motor normal operating or

		not,if not change it.
Diesel fail to start	Controller LCD display: “fail to start”, diesel rotates but can not start or diesel stop after start operating.	<ol style="list-style-type: none"> 1. Check fuel level. 2. Check DC voltage on controller no. “ 4 ” terminal, if no voltage need change controller. 3. Check the connection of fuel control magnet and the voltage on magnet. 4. Check fuse on the side of alternator. 5. Both check fuel manifold and filter jam or not. 6. If has white smoke release from exhaust system, means fuel has gone into engine, but diesel not start. Please refer to “ Diesel Manual” for further check. 7. If low ambient temp and has heat start function, please preheat first. 8. Once failure removed, press “ RESET ” button to reset control system.
Diesel high temp shutdown	Controller LCD display high temp failure icon and common failure Icon.	<ol style="list-style-type: none"> 1. Check the type of controller T-sensor correctly set or not, if error need reset. 2. Check radiator jam or not. 3. Check fan belt loose or tighten. 4. Check if ambient temperature meets generator usage range. 5. After diesel cooling, check coolant position, do not add a great deal of coolant into diesel before it is not cooling, or will cause serious damage to it. 6. Refer to “Diesel Manual” 7. Once failure removed, press “ RESET ” button to reset control system.
Low oil pressure shutdown	Controller LCD display low oil pressure failure Icon and common failure icon .	<ol style="list-style-type: none"> 1. Check the mode of controller P-sensor correctly set or not, if error need reset. 2. Check fuel level, if oil not enough, add oil. 3. Refer to “Diesel Manual” 4. Check oil pressure switch by test meter, if any problems change it. 5. Once failure removed, press “ RESET ” button to reset control system.
Diesel Over speed shutdown	Controller LCD display over speed failure icon and common failure Icon .	<ol style="list-style-type: none"> 1. Check governor speed shaft moved or not, if moved correct it. 2. If installed electronics governor, check if level shaft can freely move, correct it if necessary. 3. Refer to “Diesel Manual”.

		4. Once failure removed, press “ RESET ” button to reset control system.
Under speed shutdown	LCD display low frequency failure	<ol style="list-style-type: none"> 1. Check supply fuels enough or not. 2. Check governor speed shaft moved or not, if moved correct it. 3. If installed electronics governor, check if level shaft can freely move, correct it if necessary. 4. Adjust diesel speed when it is running. 5. Check the parameters setting for under speed failure right or not.
Low voltage shutdown	LCD display low voltage failure	<ol style="list-style-type: none"> 1. Switch off load on alternator, remove failure after shutdown and restart unit. 2. Check the setting value of Gen low voltage failure, make sure correct data. 3. If voltage still low, adjust generator output voltage by setting potentiometer to recover to normal value. 4. Refer to “Alternator Manual”
High voltage shutdown	LCD display high voltage failure	<ol style="list-style-type: none"> 1. Switch off load on alternator, remove failure after shutdown and restart unit. 2. Check the setting value of Gen high voltage failure, make sure correct data. 3. Check the measuring voltage of controller, if voltage normal, check load and make sure it is non capacitive (power factor compensation device will casual cause a capacitive load). 4. If voltage still high, adjust generator output voltage by setting potentiometer to recover tonormal value. 5. Refer to “Alternator Manual”
Engine fail not stop	Generator still running after stop, LCD display fail to stop failure	<ol style="list-style-type: none"> 1. Check fuel solenoid valve on diesel (or level shaft), make sure oil channel is completely closed under close status. 2. Check fuel control solenoid valve, change it if necessary.

11. Technical Parameters

DC supply: 8.0V to 35V continuous

Max. operating current: 12V 120mA, 24V 60mA

AC input voltage: phase voltage 30~300 V AC RMS

AC input frequency: 5~70Hz (voltage $\geq 30V$)

Control relay output: 3A/30Vdc

Operating ambient temperature: -30 to 70 °C

Storage ambient temperature: -40 to 80 °C

Fujian Fu'an Deepblue Electronic Co.,Ltd.

ADD: No.1,Jiang Jia Du Village, Fu'an City, Fujian TEL: 0593-6563990-801 Mobile: (0)13515066128

FAX: 0593-6563990-808 E-mail: info@smartcon.cn info@smartcon.com.cn QQ: 307804538

MSN: fjdeepblue@Live.cn <http://www.smartcon.cn> <http://www.smartcon.com.cn>